

## SERVICE TIP #R9

### GRINDING DISC REPLACEMENT AND CALIBRATION

Be sure to use a large, industrial flat blade screwdriver to avoid stripping the screws.

#### Removing the Old Discs:

1. **Unplug the grinder.**
2. Remove the plastic hopper and stationary plate.
  - a. 804 model grinders – loosen the rear left hopper lock screw. Hold the plastic hopper and twist it counter-clockwise 30°, and lift. Remove the screw holding the stationary plate down, and remove the plate.
  - b. 805 model grinders – unlock the hopper safety lock before twisting it up and off. Remove the top cover. Remove the discharge tube and stationary plate to reveal the lower grinding disc.
  - c. All other models – remove the screws holding the top plate on the housing, and lift the cover/hopper assembly. Remove the screws holding down the stationary plate, and remove the plate by placing your thumb in the center hold and pulling it up. If the disc does not move as you are pulling up with your thumb, tap the edge of the disc with the plastic handle of the screwdriver.
3. Remove all the screws holding on the discs. To keep the rotating disc from turning, insert the plastic handle of a tool inside the exit hole in the grinding chamber. Be careful not to damage the heads of the screws, as it would make it difficult to remove them. (**Note:** The 805 uses magnets in place of screws to hold the grinding disc in place. Place the tip of your screwdriver in the groove on the inner edge of the discs to “pop” off).
4. **Clean the areas marked “X”** with steel wool or a single edge razor blade, and make them perfectly clean. If the mating surfaces are not clean, you cannot get a fine grind.

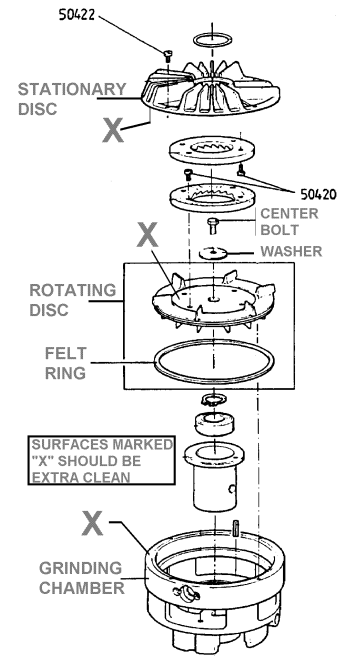

#### Installing and Calibrating the New Discs:

1. Make sure that the discs are clean with no coffee or dirt particles on the underside.
2. Check the back of the discs – newer-style machined discs are marked “top” and “bottom” for positioning.
3. If you are installing resharpened discs and you were provided spacers, use them. If you have 1 spacer, install it under the top disc. If you have 2 washers, install a spacer under each disc.
4. Install the discs, making sure the screws are tight.
5. Make sure the top edge of the grinding chamber and the underside of the stationary disc are perfectly clean.
6. Adjust the grind setting to #9.
7. Align the screw holes of the stationary disc with the grinding chamber, and insert the screws tightly.
8. Replace the cover with the plastic hopper. Now you can plug in the grinder.

CONTINUED...



U.S. Distribution Center  
8801-B Smiths Creek Rd, Wales, MI 48027  
Tel 810-367-7125 Toll-Free 800-835-5992  
Fax 810-367-7130

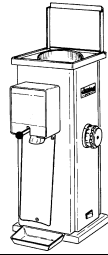

**ditting**<sup>®</sup>  
— SWISS —  
*Serving the Whole-Bean  
Coffee Market Since 1968*  
[www.ditting.com](http://www.ditting.com)

**Ref. Models:**  
804 Series  
805 Series  
903 Series  
1203 Series  
1403 Series

## SERVICE TIP #R9

# GRINDING DISC REPLACEMENT AND CALIBRATION ...CONTINUED

9. With the adjustment knob on #9, turn the grinder on with no coffee in it.
10. Turn the adjustment setting on the side to #2.
11. Loosen the center screw of the adjusting knob about 3/16<sup>th</sup> of an inch. You need to be able to pull the adjusting knob away from the machine to disengage the gear.
12. Pull out the knob and, while still in the pulled position, turn it until the #8 is in front of the red arrow. Release the adjusting knob.
13. Turn the adjusting knob **slowly** towards #1 until you hear metal scraping (the grinding discs touching). If they do not touch, repeat step #12 above.
14. When you hear the metal, turn the adjusting knob back the distance of **one line**. (Counter clockwise).
15. Pull out the adjusting knob and, while in the pulled position, place the #1 against the red arrow and release the knob. The knob will engage the internal gear.
16. Position the aluminum cover on the adjusting knob to fit in the groove, and tighten the center screw.
17. Your grinder should now be adjusted properly, and all settings should match the proper grinds.

**Testing the grind:** Place 10-15 beans in the hopper and grind on the #1 setting. The output must be pulverized (powder).

**Notes:** If on the #1 setting the coffee comes out slowly or in small balls, the setting is too close. Repeat the above procedure. If the grinding is still too slow, replace the grinding discs.

**Special:** If you want to calibrate the grinder to grind coarser coffee than Ditting's French Press setting AND you will not need to grind Turkish, turn the adjusting knob back TWO lines in step #14. If you need even coarser coffee after you have tested it, repeat the process and turn back 2 ½ - 3 lines in step #14.